



Vessel name	Built	IMO no.	Flag	Vessel name	Built	IMO no.	Flag
BBC Kwiatkowski	2008	9436953	Antigua & Barbuda	BBC Polonia	2010	9415325	Antigua & Barbuda
BBC Gdansk	2009	9436965	Antigua & Barbuda				

MAIN DATA

Vessel type	Multipurpose Heavylifter
Classification	GL + 100 A5 E3 + MC E3 AUT strengthened for heavy cargoes, equipped for the carriage of containers, equipped for the carriage of dangerous goods
GT/NT	6,155 / 2,759
Deadweight (summer)	7,700 mt
Max. draft (summer)	7.15 m
Length o.a.	122.45 m
Length between pp.	115.63 m
Breadth moulded	18.20 m
Depth to main deck	9.70 m
Height above keel	41.00 m
Max. Speed	15.0 knots
Fuel consumption	18.5 mt RMG 380 fuel per day at sea 1.75 mt MGO DMA per day in port without gear 4.75 mt MGO DMA per day in port with gear

HOLDS/HATCHES/CRANES

Cargo hold capacity	9,856 cbm / 348,268 cbft
Floor space under deck	1,854 sqm / 19,956 sqft
Floor space on deck	1,003 sqm / 10,796 sqft
Cranes	2 NMF cranes situated portside 120 mt capacity each / 240 mt capacity combined
Container intake	532 TEU nominal 262 TEU at 14 mt homogeneously loaded 32 reefer plugs on deck
Deck strengths per sqm	18.00 mt on tanktop 2.50 mt on tweendeck 2.80 mt on hatchcovers

SPECIAL EQUIPMENT/FEATURES

Fitted for trading Great Lakes and Australia.
Fitted for carriage of dangerous goods of all IMO classes.

Crane working area SWL 120t

BBC Kwiatkowski BBC Polonia
BBC Gdansk

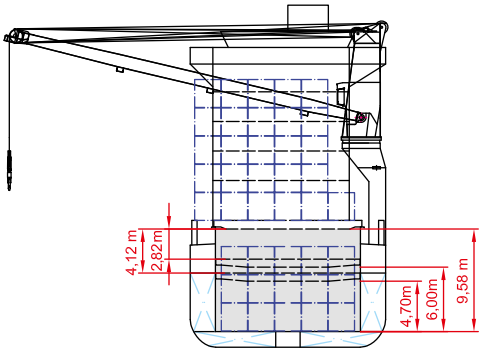

SIDE VIEW

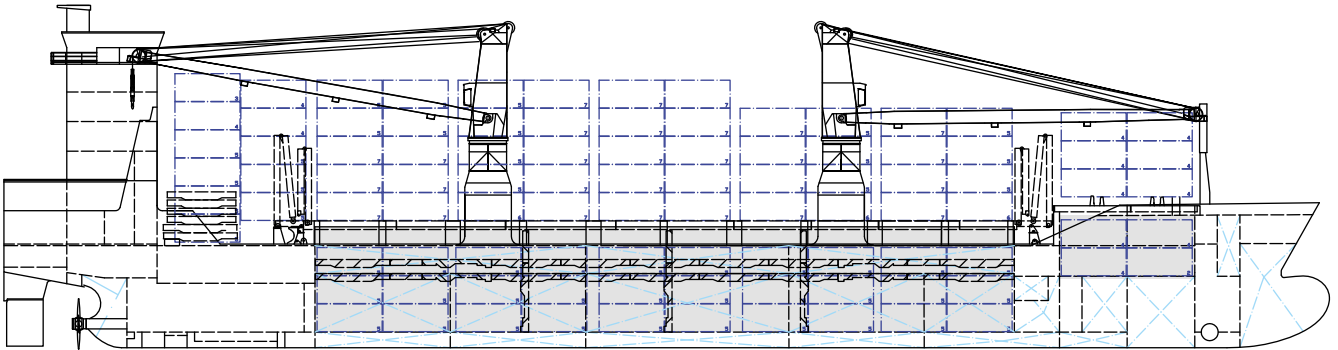

MAIN DECK

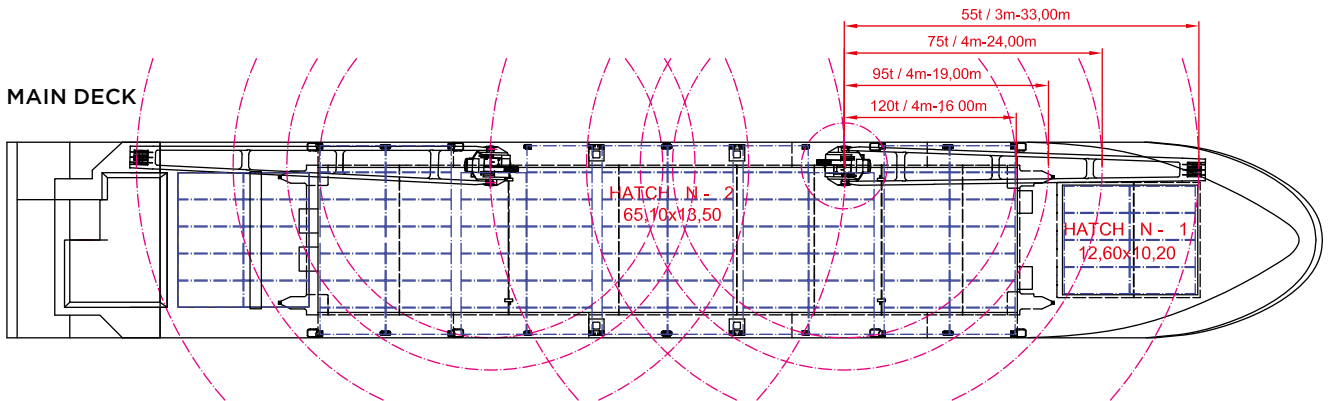

TWEENDECK

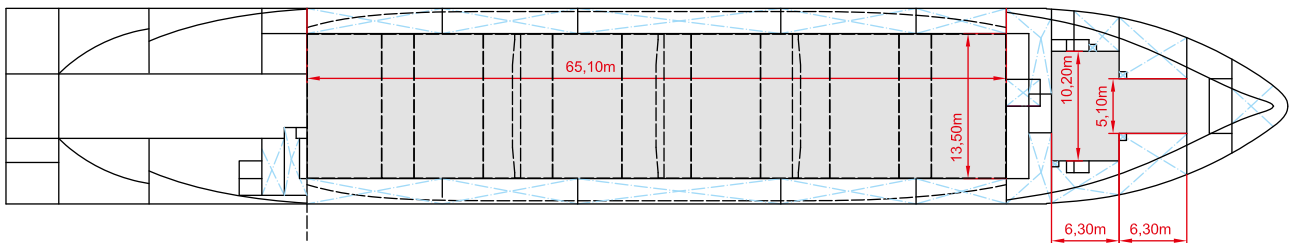

HOLDS & DOUBLE BOTTOM

