



Vessel name	Built	IMO no.	Flag	Vessel name	Built	IMO no.	Flag
BBC Congo	2010	9436331	Antigua & Barbuda	BBC Nile	2011	9571375	Antigua & Barbuda
BBC Ganges	2010	9508304	Antigua & Barbuda	BBC Parana	2012	9571387	Antigua & Barbuda
BBC Oder	2010	9508316	Antigua & Barbuda	BBC Danube	2013	9571399	Antigua & Barbuda
BBC Seine	2010	9508380	Antigua & Barbuda				

MAIN DATA

Vessel type	Multipurpose Heavy-lifter
Classification	GL + 100 A5 ICE E3 G + MC E3 AUT strengthened for heavy cargoes, equipped for the carriage of containers, equipped for the carriage of dangerous goods
GT/NT	12,974 / 5,334
Deadweight (summer)	17,000 mt
Max. draft (summer)	9.70 m
Length o.a.	143.14 m
Length between pp.	134.43 m
Breadth moulded	22.80 m
Depth to main deck	13.30 m
Height above keel	41.40 m
Max. Speed	15.0 knots
Fuel consumption	30.0 mt RMG 380 fuel per day at sea 2.1 mt MGO DMA per day in port without gear 4.7 mt MGO DMA per day in port with gear

HOLDS/HATCHES/CRANES

Cargo hold capacity	19,777 cbm / 698,429 cbft
Floor space under deck	2,986 sqm / 32,141 sqft
Floor space on deck	1,486 sqm / 16,002 sqft
Cranes	3 NMF cranes situated portside 2 x 250 mt + 1 x 80 mt capacity each 500 mt capacity combined
Container intake	958 TEU nominal 617 TEU at 14 mt homogeneously loaded 60 reefer plugs on deck
Deck strengths per sqm	20.00 mt on tanktop 4.70 mt on tweendeck 2.20 mt on hatchcovers

SPECIAL EQUIPMENT/FEATURES

Fitted for trading Australia.
Fitted for carriage of dangerous goods of all IMO classes.

Crane working area SWL 100t

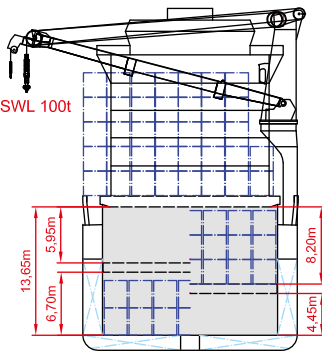

BBC Congo	BBC Nile
BBC Ganges	BBC Parana
BBC Oder	BBC Danube
BBC Seine	

SIDE VIEW

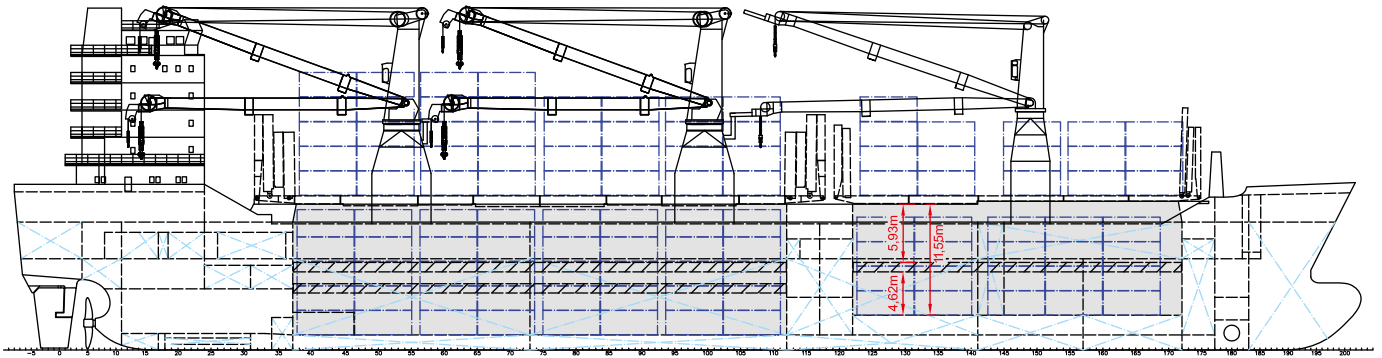

MAIN DECK

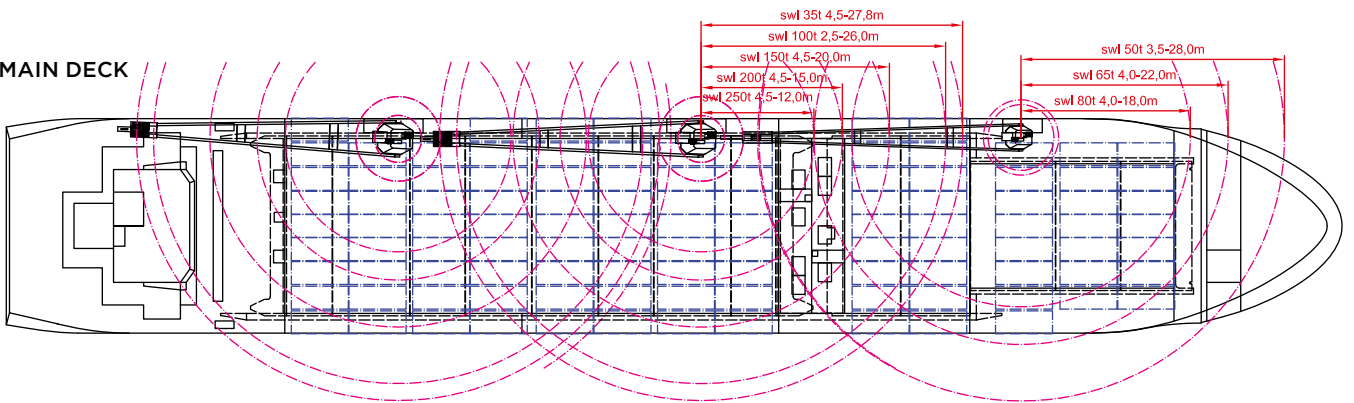

TWEENDECK

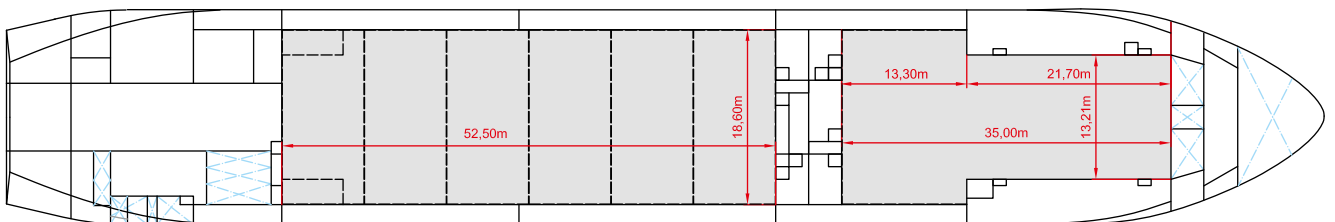

HOLDS & DOUBLE BOTTOM

