



Vessel name	Built	IMO no.	Flag	Vessel name	Built	IMO no.	Flag
BBC Maine	2007	9357200	Antigua & Barbuda	BBC Vermont	2008	9357236	Antigua & Barbuda
BBC Delaware	2007	9357212	Antigua & Barbuda	BBC Florida	2009	9433286	Antigua & Barbuda
BBC Carolina	2007	9402043	Antigua & Barbuda	BBC Maryland	2010	9433298	Antigua & Barbuda
Lisa Auerbach	2008	9388900	Liberia	BBC Michigan	2010	9501241	Antigua & Barbuda
Leanne Auerbach	2008	9388912	Liberia	Claude A. Desgagnes	2011	9488059	Barbados
BBC Georgia	2008	9357224	Antigua & Barbuda	BBC Arizona	2010	9501253	Antigua & Barbuda

MAIN DATA

Vessel type	Multipurpose Heavylifter
Classification	GL + 100 A5 MPV E3 G IW BWM-F + MCE3 AUT strengthened for heavy cargoes, equipped for the carriage of containers, equipped for the carriage of dangerous goods NKK - NS, MNS (MO), IWS, BWTS, GRAB, Ice Class IA, equipped for the carriage of dangerous goods (BBC Florida, BBC Georgia, BBC Vermont)
GT/NT	9,620 / 4,260
Deadweight (summer)	12,780 mt
Max. draft (summer)	8.00 m
Length o.a.	138.50 m
Length between pp.	130.71 m
Breadth moulded	21.00 m
Depth to main deck	11.00 m
Height above keel	40.09 m
Max. Speed	15.0 knots
Fuel consumption	25.0 mt RMG 380 fuel per day at sea 2.5 mt MGO DMA per day in port without gear 3.0 mt MGO DMA per day in port with gear

HOLDS/HATCHES/CRANES

Cargo hold capacity	15,952 cbm / 563,340 cbft
Floor space under deck	2,810 sqm / 30,247 sqft
Floor space on deck	1,480 sqm / 15,931 sqft
Cranes	2 NMF cranes situated portside 150 mt capacity each / 300 mt capacity combined
Container intake	665 TEU nominal 528 TEU at 14 mt homogeneously loaded 50 reefer plugs on deck
Deck strengths per sqm	16.00 mt on tanktop 2.50 mt on tweendeck in hold 1 and hold 2 (upper position) 4.00 mt on tweendeck in hold 2 (middle and lower position) and hold 3 1.75 mt on hatchcovers

SPECIAL EQUIPMENT/FEATURES

Fitted for trading Great Lakes and Australia.
Fitted for carriage of dangerous goods of all IMO classes.

Speed and consumption figures are calculated basis maximum Beaufort 2, no swell and no adverse currents. Consumption data assumes shaft generator and reefer plugs disconnected. Vessel is burning fuels according to ISO 8217-2005. Intake is always subject to vessel's stability, trim, permissible weights and is subject to regulations of visibility. Lifting capacity of vessel's cranes is subject to vessel's stability and can depend on cargo/ballast on board. Container data as well as bale capacity assumes tweendeck ashore. All details including speed and consumption are given in good faith and are „about“ and are given without guarantee. They must not be used as basis for charterparties or contracts without BBC's explicit written authority.

BBC Maine	BBC Vermont
BBC Delaware	BBC Florida
BBC Carolina	BBC Maryland
Lisa Auerbach	BBC Michigan
Leanne Auerbach	Claude A. Desgagnes
BBC Georgia	BBC Arizona

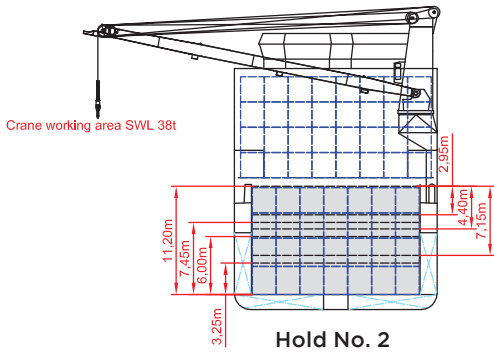
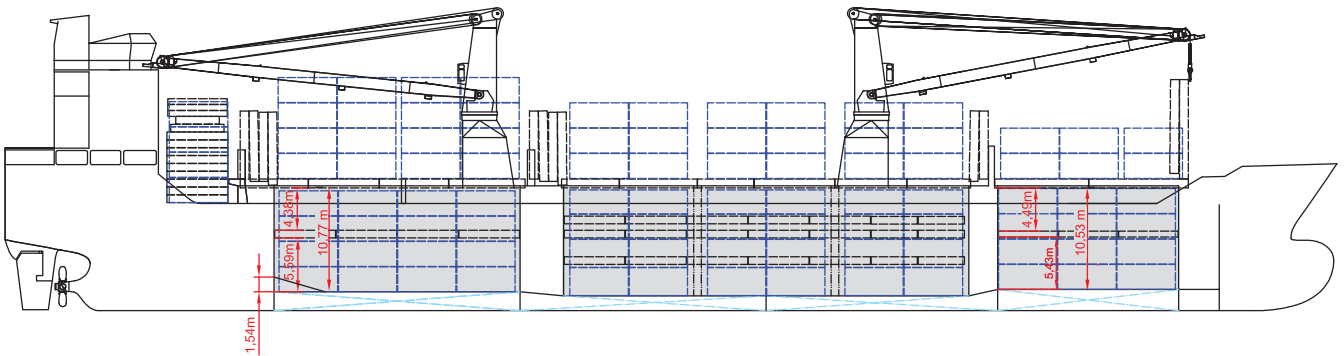
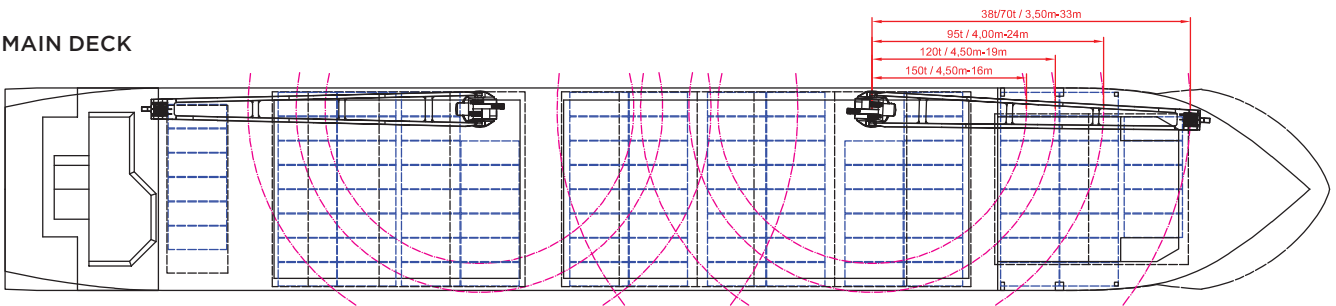
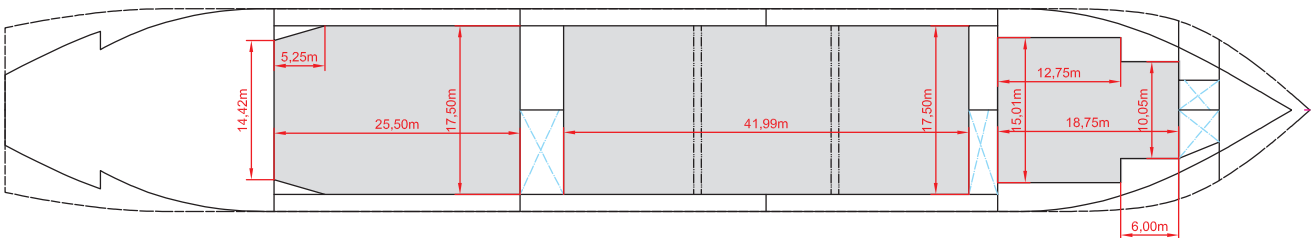
SIDE VIEW

MAIN DECK

TWEENDECK

HOLDS & DOUBLE BOTTOM
