



Vessel name	Built	IMO no.	Flag	Vessel name	Built	IMO no.	Flag
BBC Nagasaki	2011	9559872	Antigua & Barbuda	BBC Nyhavn	2012	9559896	Antigua & Barbuda
BBC Norfolk	2012	9559884	Antigua & Barbuda				

MAIN DATA

Vessel type	Multipurpose Tweendecker
Classification	BV + HULL + MACH + AUT-UMS, + ICE CLASS IA strengthened for heavy cargoes, equipped for the carriage of containers, equipped for the carriage of dangerous goods
GT/NT	6,351 / 3,617
Deadweight (summer)	9,821 mt
Max. draft (summer)	7.73 m
Length o.a.	132.15 m
Length between pp.	124.56 m
Breadth moulded	15.87 m
Depth to main deck	9.65 m
Height above keel	37.50 m
Max. Speed	13.5 knots
Fuel consumption	14.5 mt RMG 380 fuel per day at sea 1.3 mt MGO DMA per day in port without gear 2.3 mt MGO DMA per day in port with gear

HOLDS/HATCHES/CRANES

Cargo hold capacity	12,822 cbm / 451,898 cbft
Floor space under deck	2,320 sqm / 24,972 sqft
Floor space on deck	1,248 sqm / 13,433 sqft
Cranes	2 cranes situated portside 60 mt capacity each/ 120 mt capacity combined
Container intake	474 TEU nominal 333 TEU at 14 mt homogeneously loaded 20 reefer plugs on deck
Deck strengths per sqm	15.00 mt on tanktop 3.50 mt on tweendeck 1.75 mt on hatchcovers

SPECIAL EQUIPMENT/FEATURES

Fitted for trading Great Lakes and Australia.
Fitted for carriage of dangerous goods of all IMO classes.

Speed and consumption figures are calculated basis maximum Beaufort 2, no swell and no adverse currents. Consumption data assumes shaft generator and reefer plugs disconnected. Vessel is burning fuels according to ISO 8217-2012. Intake is always subject to vessel's stability, trim, permissible weights and is subject to regulations of visibility. Lifting capacity of vessel's cranes is subject to vessel's stability and can depend on cargo/ballast on board. Container data as well as bale capacity assumes tweendeck ashore. All details including speed and consumption are given in good faith and are „about“ and are given without guarantee. They must not be used as basis for charterparties or contracts without BBC's explicit written authority.

BBC Nagasaki
BBC Norfolk

BBC Nyhavn

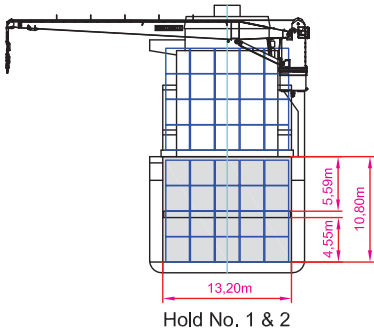

SIDE VIEW

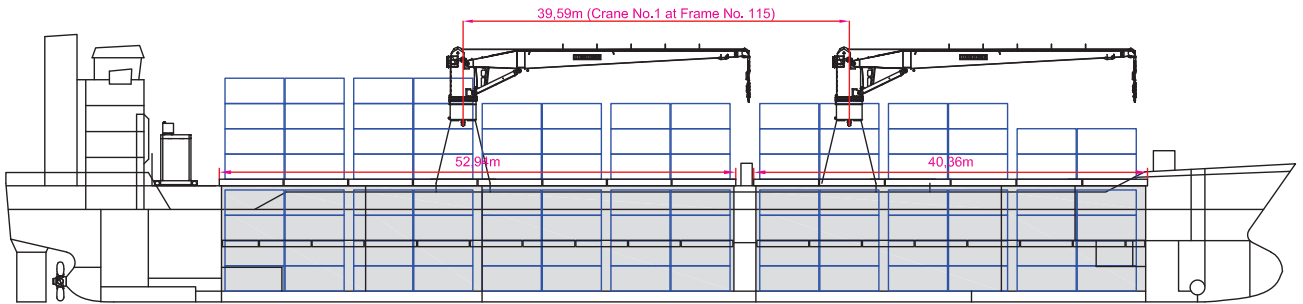

MAIN DECK

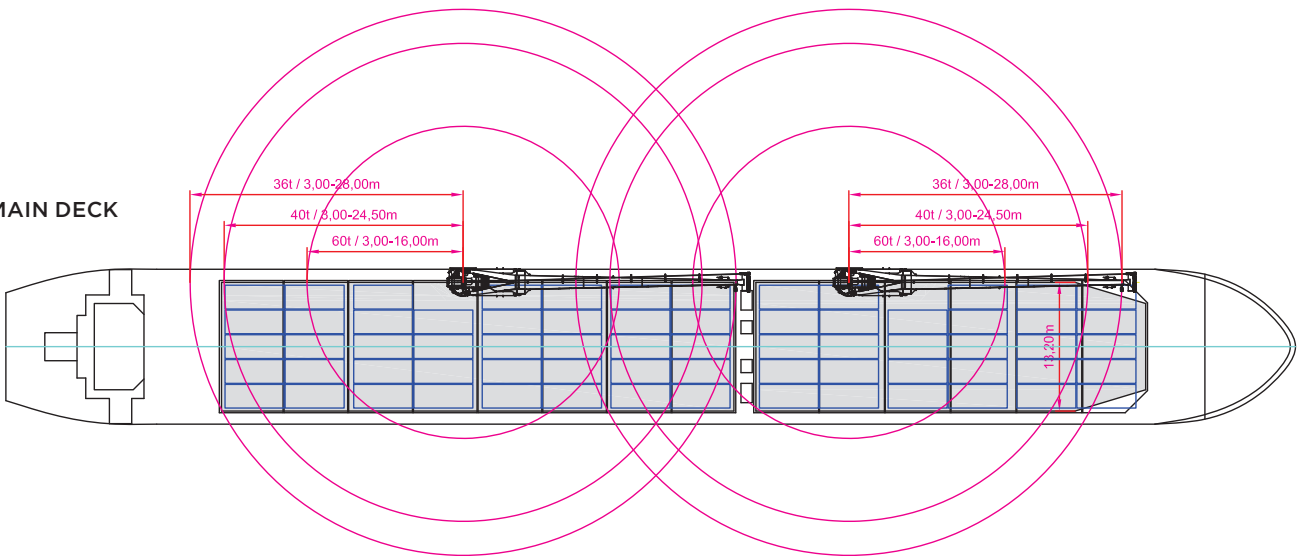

TWEENDECK

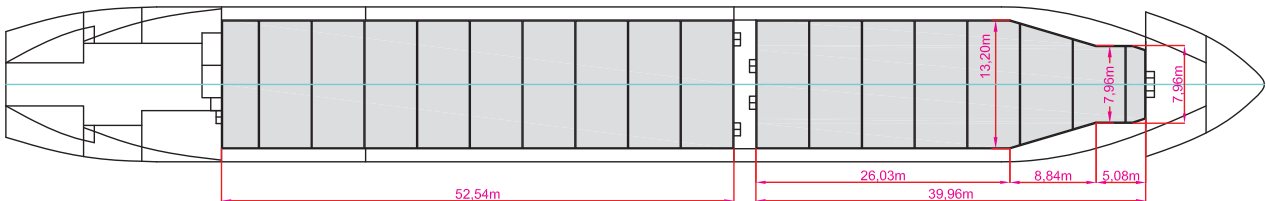

HOLDS & DOUBLE BOTTOM

