



Vessel name	Built	IMO no.	Flag	Vessel name	Built	IMO no.	Flag
BBC Everest	2011	9508407	Germany	BBC Olympus	2012	9508457	Antigua & Barbuda
BBC Fuji	2011	9508419	Germany	BBC Rushmore	2012	9508469	Antigua & Barbuda
BBC Kibo	2011	9508421	Antigua & Barbuda	BBC Vesuvius	2012	9508471	Antigua & Barbuda
BBC Mont Blanc	2011	9508433	Antigua & Barbuda	BBC Xingang	2013	9508483	Antigua & Barbuda

MAIN DATA

Vessel type	Multipurpose Heavylifter
Classification	GL + 100 A5 E G BWM + SOLAS II MC E AUT
GT/NT	8,255 / 3,966
Deadweight (summer)	9,282 mt
Max. draft (summer)	7.60 m
Length o.a.	125.80 m
Length between pp.	119.66 m
Breadth moulded	22.00 m
Depth to main deck	10.80 m
Height above keel	38.15 m
Max. Speed	16.5 knots
Fuel consumption	24.0 mt RMG 380-cst fuel per day at sea 1.5 mt MGO DMA per day in port without gear 2.5 mt MGO DMA per day in port with gear

HOLDS/HATCHES/CRANES

Cargo hold capacity	13,119 cbm / 463,293 cbft
Floor space under deck	2,286 sqm / 24,606 sqft
Floor space on deck	1,245 sqm / 13,401 sqft
Cranes	2 NMF cranes situated portside 350 mt capacity each / 700 mt capacity combined
Container intake	660 TEU nominal 377 TEU at 14 mt homogeneously loaded 60 reefer plugs
Deck strengths per sqm	16.00 mt on tanktop 2.50 mt on tweendeck Hold 1 3.00 mt on tweendeck Hold 2 2.50 mt on hatchcovers

SPECIAL EQUIPMENT/FEATURES

Fitted for trading Great Lakes and Australia.
Fitted for carriage of dangerous goods of all IMO classes.
Not grain fitted.

Speed and consumption figures are calculated basis maximum Beaufort 2, no swell and no adverse currents. Consumption data assumes shaft generator and reefer plugs disconnected. Vessel is burning fuels according to ISO 8217-2012. Intake is always subject to vessel's stability, trim, permissible weights and is subject to regulations of visibility. Lifting capacity of vessel's cranes is subject to vessel's stability and can depend on cargo/ballast on board. Container data as well as bale capacity assumes tweendeck ashore. All details including speed and consumption are given in good faith and are „about“ and are given without guarantee. They must not be used as basis for charterparties or contracts without BBC's explicit written authority.

BBC Everest	BBC Olympus
BBC Fuji	BBC Rushmore
BBC Kibo	BBC Vesuvius
BBC Mont Blanc	BBC Xingang

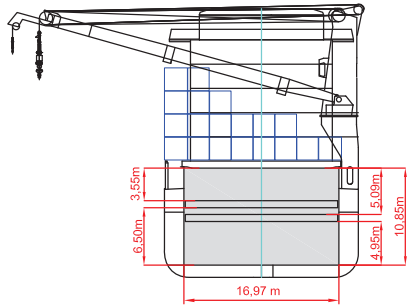

Hold No. 2

SIDE VIEW

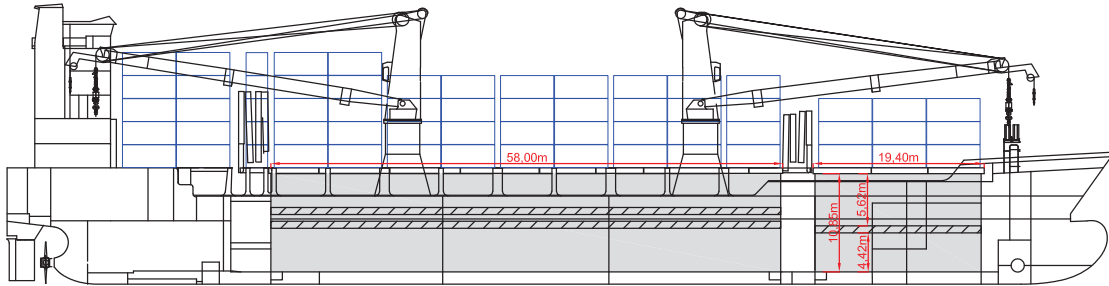

MAIN DECK

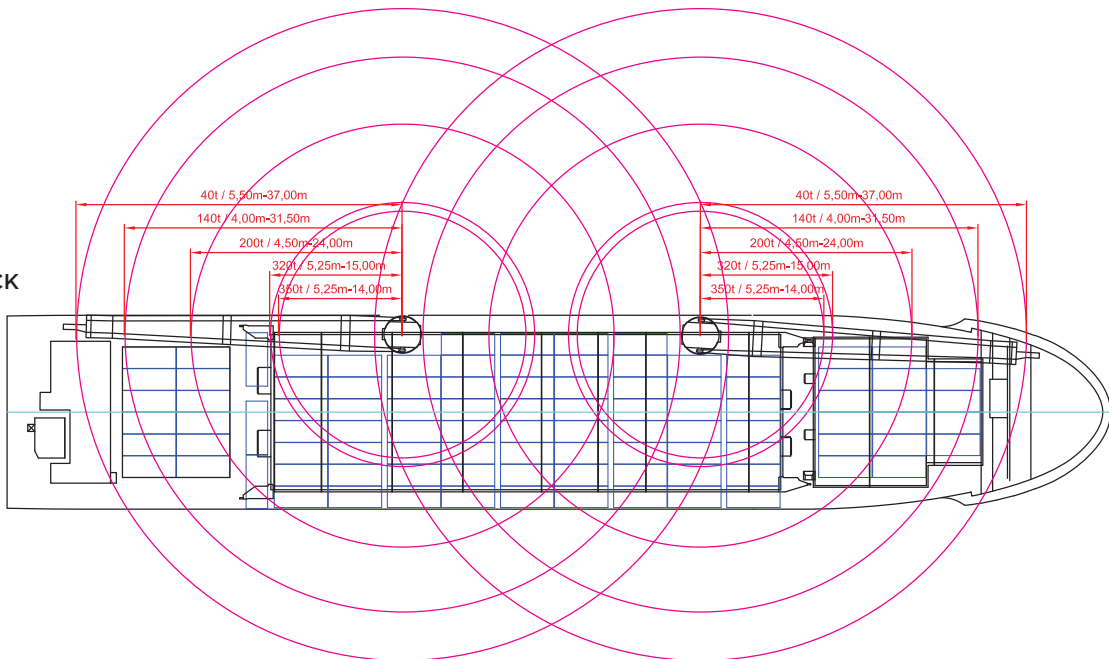

TWEENDECK

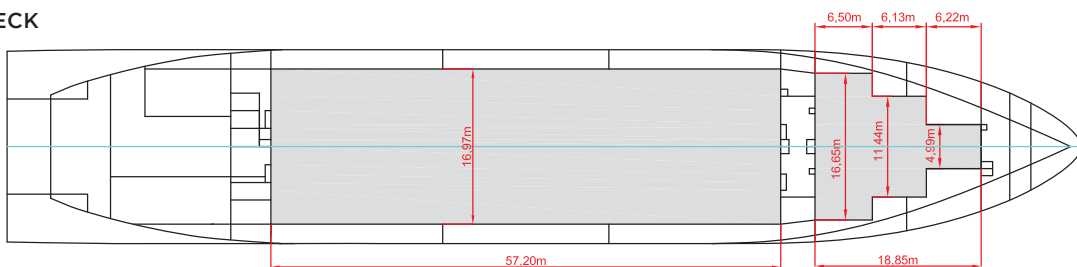

HOLDS & DOUBLE BOTTOM

