

BBC-7K-500A



VESSEL NAME	BUILT	IMO NO.	FLAG	VESSEL NAME	BUILT	IMO NO.	FLAG
BBC Europe	2003	9266308	Antigua & Barbuda	BBC Scandinavia	2007	9362633	Antigua & Barbuda
BBC Germany	2003	9297096	Gibraltar	BBC Greenland	2007	9427079	Antigua & Barbuda
BBC Asia	2003	9266310	Antigua & Barbuda	BBC Switzerland	2008	9433315	Germany
Thunder Bird ⁽¹⁾	2004	9318943	Denmark	BBC Austria ⁽¹⁾	2009	9433327	Antigua & Barbuda
BBC Africa	2006	9362621	Antigua & Barbuda				

MAIN DATA

TYPE	
Vessel type	Multipurpose Heavylifter
Classification	DNV
TONNAGE	
Deadweight (summer)	7,500 mt
GT / NT	7,014 / 3,375
DIMENSIONS	
Max. draft (summer)	7.60 m
Length o.a.	119.80 m
Length between pp.	113.75 m
Breadth moulded	20.20 m
Depth to main deck	9.70 m
Height above keel	38.15 m
SPEED	
Max. speed	15.50 knots
Intermediate speed	14.50 knots
Reduced speed 	13.50 knots

HOLDS / HATCHES / CRANES

CARGO GEAR		
Crane manufacturer	NMF	(portside)
Lifting capacity	2 x 250 mt	
CONTAINER CAPACITY		
Nominal capacity	599 TEU	
At 14 mt homog. loaded	377 TEU	
Stackweights on deck	20' = 60.00 mt	40' = 80.00 mt
Stackweights tanktop	20' = 100.00 mt	40' = 120.00 mt
Reefer plugs	60	
DECK STRENGTHS		
Tanktop	16.00 mt / sqm	
Tweendeck hold 1	2.50 mt / sqm	
Tweendeck hold 2	3.00 mt / sqm	
Hatchcovers	2.50 mt / sqm	
HOLDS / HATCHES		
Cargo hold capacity	11,021 cbm	389,040 cbft
Floor space under deck	1,986 sqm	21,377 sqft
Floor space on deck	1,083 sqm	11,657 sqft

SPECIAL EQUIPMENT / FEATURES



Great Lakes fitted



Australia fitted



IMO Class 1-9 fitted



Stability pontoon



Mix type hatch cover



Automatic mode



⁽¹⁾ IMO 7 / INF2 fitted

BBC-7K-500A

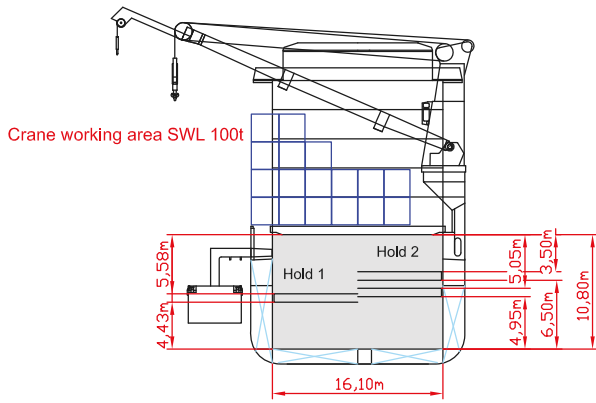

SIDE VIEW

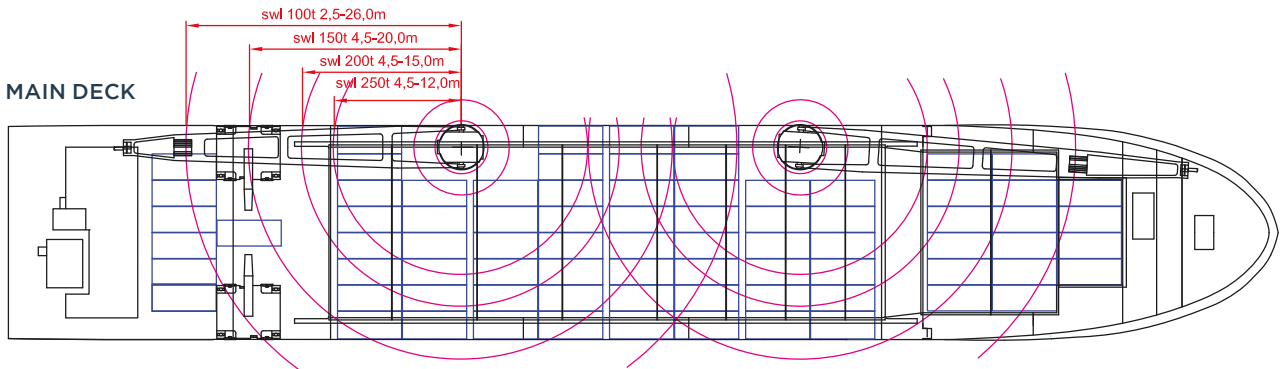
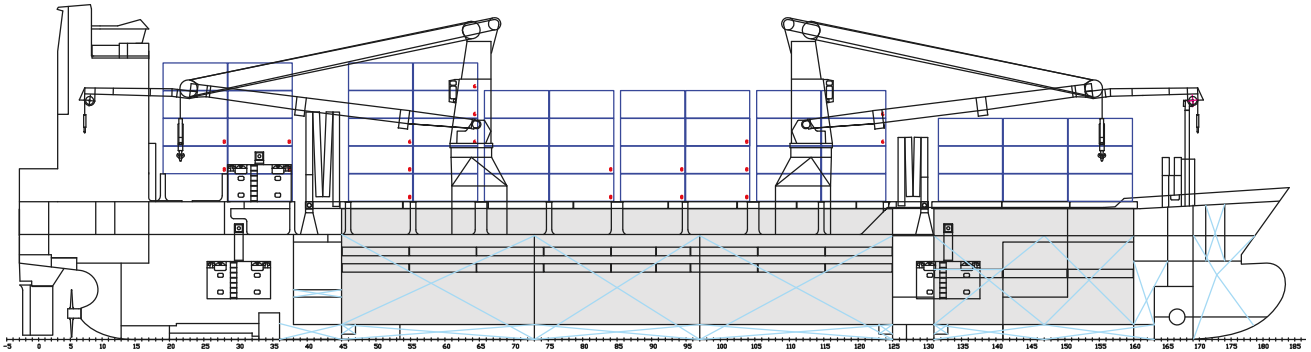

TWEENDECK

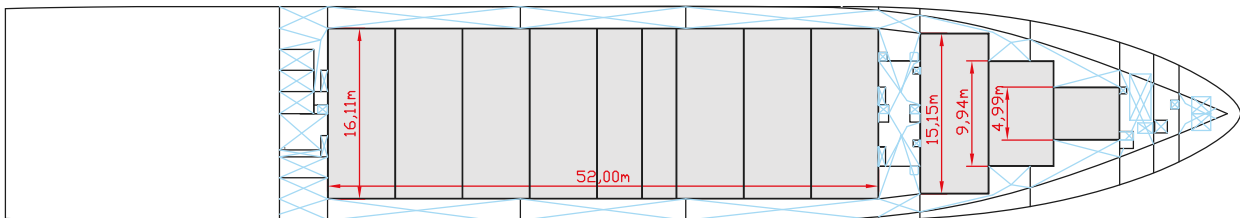

HOLDS & DOUBLE BOTTOM

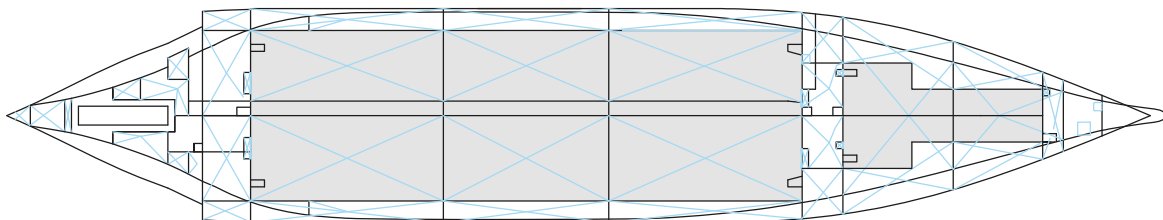

Speed figures are calculated basis maximum Beaufort 2, no swell and no adverse currents. Intake is always subject to vessel's stability, trim, permissible weights and is subject to regulations of visibility. Lifting capacity of vessel's cranes is subject to vessel's stability and can depend on cargo/ballast on board. Container data as well as cargo hold capacity assumes tweendeck ashore. All details including speed are given in good faith and can vary on the individual vessels. They are to be considered „about“, are given without guarantee and must not be used as basis for charterparties or contracts without BBC Chartering's explicit written authority.