

BBC-7K-240A



VESSEL NAME	BUILT	IMO NO.	FLAG	VESSEL NAME	BUILT	IMO NO.	FLAG
BBC Kwiatkowski	2008	9436953	Antigua & Barbuda	BREB Star	2010	9415325	Antigua & Barbuda
BBC Gdansk	2009	9436965	Antigua & Barbuda				

MAIN DATA

TYPE	
Vessel type	Multipurpose Heavylifter
Classification	DNV
TONNAGE	
Deadweight (summer)	7,700 mt
GT / NT	6,155 / 2,759
DIMENSIONS	
Max. draft (summer)	7.15 m
Length o.a.	122.45 m
Length between pp.	115.63 m
Breadth moulded	18.20 m
Depth to main deck	9.70 m
Height above keel	41.00 m
SPEED	
Max. speed	14.00 knots
Intermediate speed	13.00 knots
Reduced speed 	12.00 knots

HOLDS / HATCHES / CRANES

CARGO GEAR		
Crane manufacturer	NMF	(portside)
Lifting capacity	2 x 120 mt	
CONTAINER CAPACITY		
Nominal capacity	532 TEU	
At 14 mt homog. loaded	262 TEU	
Stackweights on deck	20' = 40.00 mt	40' = 50.00 mt
Stackweights tanktop	20' = 61.00 mt	40' = 60.00 mt
Reefer plugs	32	
DECK STRENGTHS		
Tanktop	18.00 mt / sqm	
Tweendeck	2.50 mt / sqm	
Hatchcovers	2.80 mt / sqm	
HOLDS / HATCHES		
Cargo hold capacity	9,058 cbm	348,268 cbft
Floor space under deck	1,854 sqm	19,956 sqft
Floor space on deck	1,003 sqm	10,796 sqft

SPECIAL EQUIPMENT / FEATURES



Ice Class
E3/A1



Grain
fitted



Great Lakes
fitted



Australia
fitted



IMO Class 1-9
fitted



Mix type
hatch cover



Automatic
mode

BBC-7K-240A

Crane working area SWL 120t

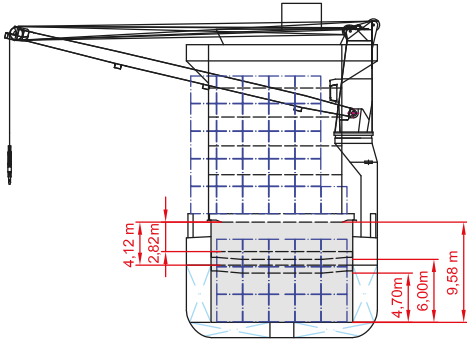

SIDE VIEW

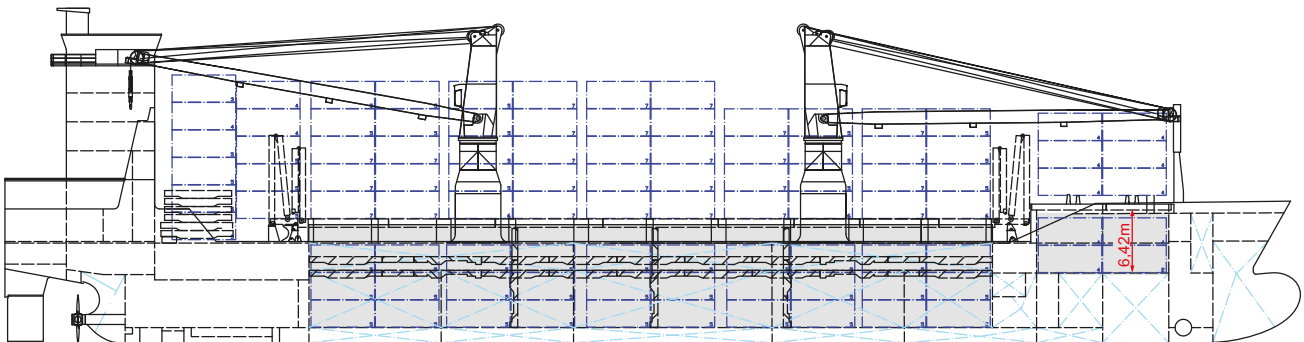

MAIN DECK

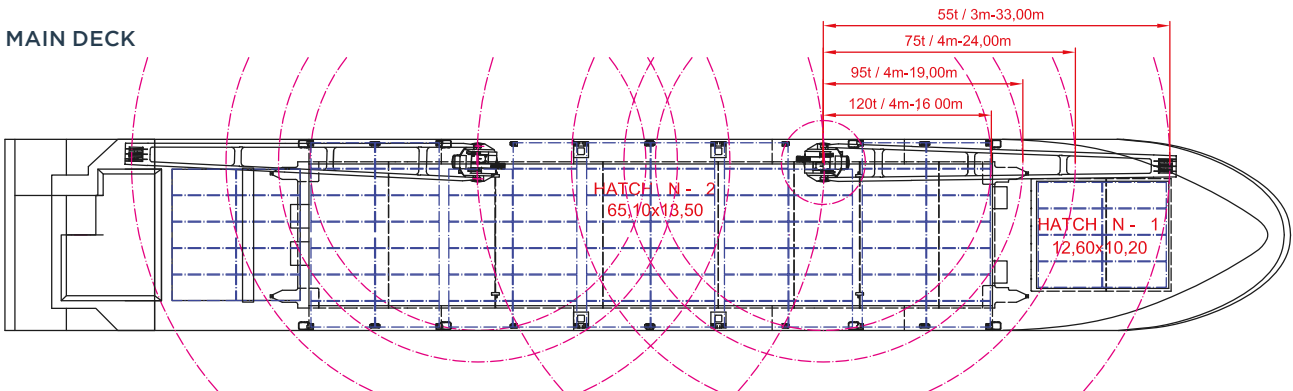

TWEENDECK

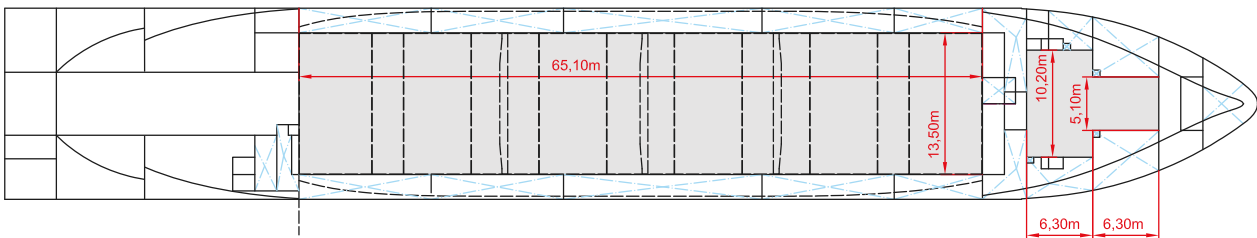

HOLDS & DOUBLE BOTTOM

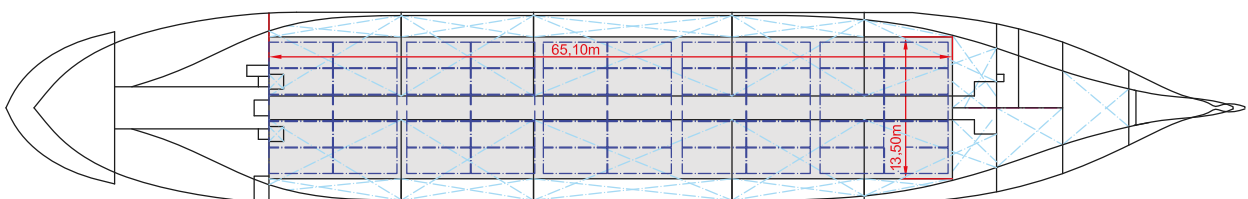

Speed figures are calculated basis maximum Beaufort 2, no swell and no adverse currents. Intake is always subject to vessel's stability, trim, permissible weights and is subject to regulations of visibility. Lifting capacity of vessel's cranes is subject to vessel's stability and can depend on cargo/ballast on board. Container data as well as cargo hold capacity assumes tweendeck ashore. All details including speed are given in good faith and can vary on the individual vessels. They are to be considered „about“, are given without guarantee and must not be used as basis for charterparties or contracts without BBC Chartering's explicit written authority.