



Vessel name	Built	IMO no.	Flag
BBC Jade	2007	9421116	Antigua & Barbuda

MAIN DATA

Vessel type	Multipurpose Tweendecker
Classification	LR + 100 A1 + LMC UMS SCM Ice Class 1A strengthened for heavy cargoes, equipped for the carriage of containers, equipped for the carriage of dangerous goods
GT/NT	8,999 / 4,600
Deadweight (summer)	12,000 mt
Max. draft (summer)	7.90 m
Length o.a.	142.95 m
Breadth moulded	18.90 m
Depth to main deck	10.95 m
Height above keel	42.92 m
Speed	15.0 knots
Fuel consumption	23.0 mt RMG 380 fuel per day at sea 1.5 mt MGO DMA per day in port without gear 3.0 mt MGO DMA per day in port with gear

HOLDS/HATCHES/CRANES

Cargo hold capacity	17,257 cbm / 609,424 cbft
Floor space under deck	2,844 sqm / 30,612 sqft
Floor space on deck	1,459 sqm / 15,704 sqft
Cranes	2 Liebherr cranes situated starboardside 80 mt capacity each / 160 mt capacity combined
Container intake	684 TEU nominal 455 TEU at 14 mt homogeneously loaded 80 reefer plugs
Deck strengths per sqm	18.00 mt on tanktop 4.00 mt on tweendeck 2.00 mt on hatchcovers

>>> see reverse side for further info/details

SPECIAL EQUIPMENT/FEATURES

Fitted for trading Great Lakes and Australia.
Fitted for carriage of dangerous goods of all IMO classes.

Speed and consumption figures are calculated basis maximum Beaufort 2, no swell and no adverse currents. Consumption data assumes shaft generator and reefer plugs disconnected. Vessel is burning fuels according to ISO 8217-2005. Intake is always subject to vessel's stability, trim, permissible weights and is subject to regulations of visibility. Lifting capacity of vessel's cranes is subject to vessel's stability and can depend on cargo/ballast on board. Container data as well as bale capacity assumes tweendeck ashore. All details including speed and consumption are given in good faith and are „about“ and are given without guarantee. They must not be used as basis for charterparties or contracts without BBC's explicit written authority.

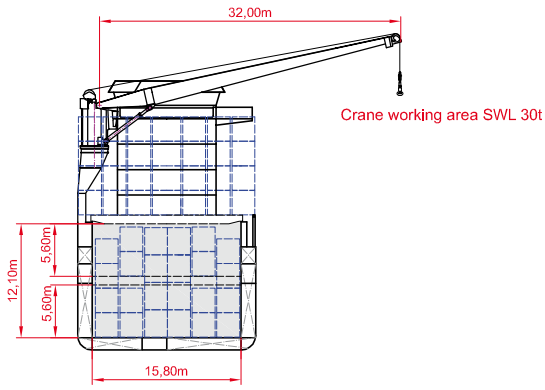
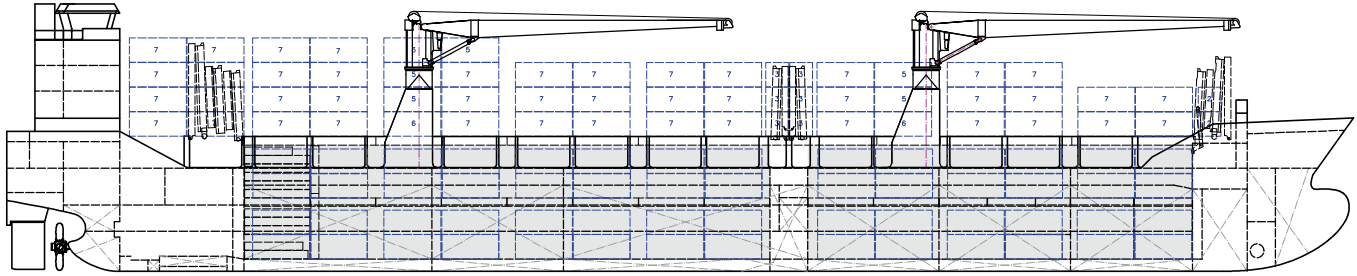
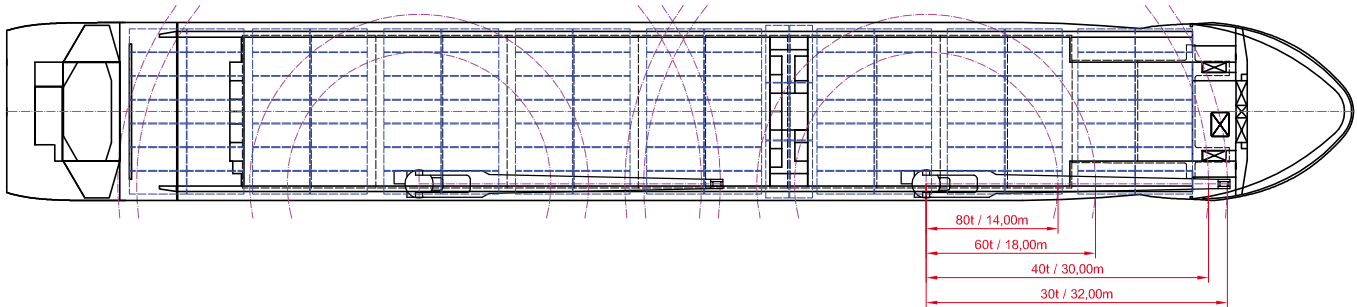
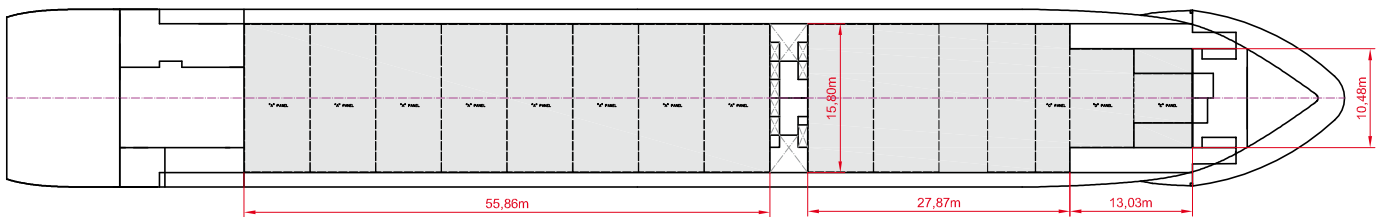
SIDE VIEW

MAIN DECK

TWEENDECK

HOLDS & DOUBLE BOTTOM
