



Vessel name	Built	IMO no.	Flag	Vessel name	Built	IMO no.	Flag
BBC Emsland	2010	9511648	Antigua & Barbuda	BBC Haren	2010	9511636	Antigua & Barbuda

MAIN DATA

Vessel type	Multipurpose Tweendecker
Classification	LR + 100 A1 + LMC UMS SCM NAV1 Ice Class 1A strengthened for heavy cargoes, equipped for the carriage of containers, equipped for the carriage of dangerous goods
GT/NT	7,878 / 3,909
Deadweight (summer)	11,000 mt
Max. draft (summer)	7.40 m
Length o.a.	145.63 m
Breadth moulded	18.25 m
Depth to main deck	10.30 m
Height above keel	36.40 m
Speed	14.0 knots
Fuel consumption	18.0 mt RMG 380 fuel per day at sea 1.3 mt MGO DMA per day in port without gear 2.2 mt MGO DMA per day in port with gear

HOLDS/HATCHES/CRANES

Cargo hold capacity	14,807 cbm / 522,904 cbft
Floor space under deck	2,641 sqm / 28,427 sqft
Floor space on deck	1,379 sqm / 14,843 sqft
Cranes	2 Liebherr cranes situated starboard 80 mt capacity each / 140 mt capacity combined
Container intake	671 TEU nominal 457 TEU at 14 mt homogeneously loaded 60 reefer plugs on deck
Deck strengths per sqm	18.00 mt on tanktop 3.50 mt on tweendeck

>>> see reverse side for further info/details

SPECIAL EQUIPMENT/FEATURES

Fitted for trading Great Lakes and Australia.
Fitted for carriage of dangerous goods of all IMO classes.

Speed and consumption figures are calculated basis maximum Beaufort 2, no swell and no adverse currents. Consumption data assumes shaft generator and reefer plugs disconnected. Vessel is burning fuels according to ISO 8217-2005. Intake is always subject to vessel's stability, trim, permissible weights and is subject to regulations of visibility. Lifting capacity of vessel's cranes is subject to vessel's stability and can depend on cargo/ballast on board. Container data as well as bale capacity assumes tweendeck ashore. All details including speed and consumption are given in good faith and are „about“ and are given without guarantee. They must not be used as basis for charterparties or contracts without BBC's explicit written authority.

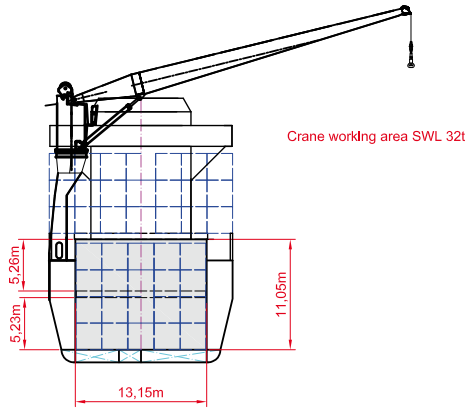

SIDE VIEW

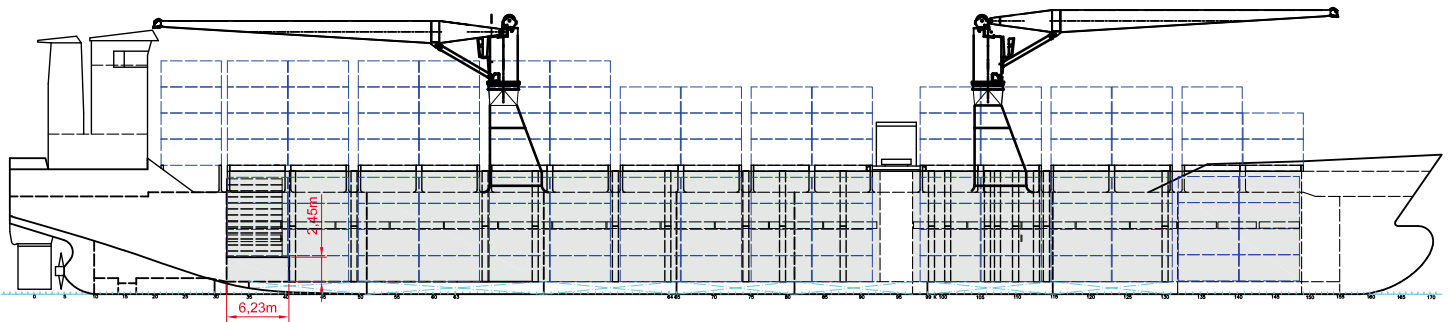

MAIN DECK

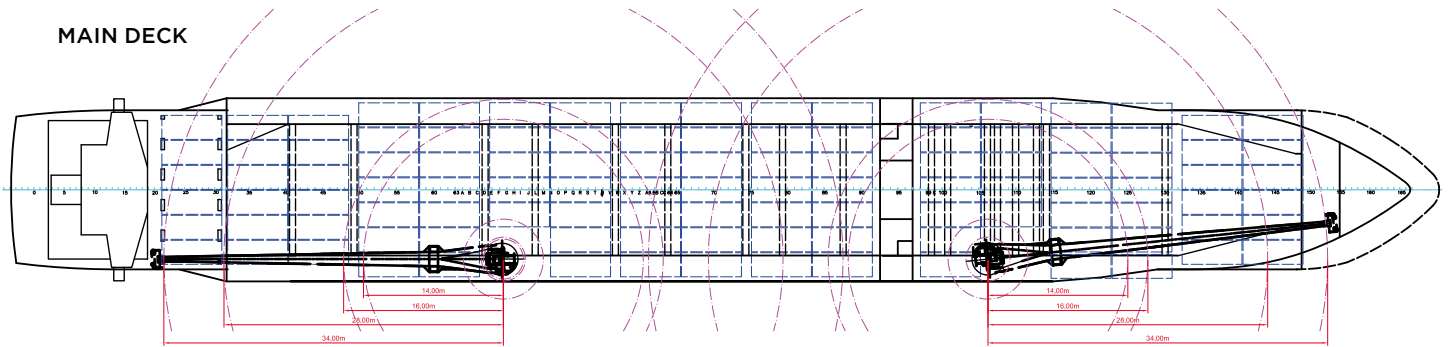

TWEENDECK

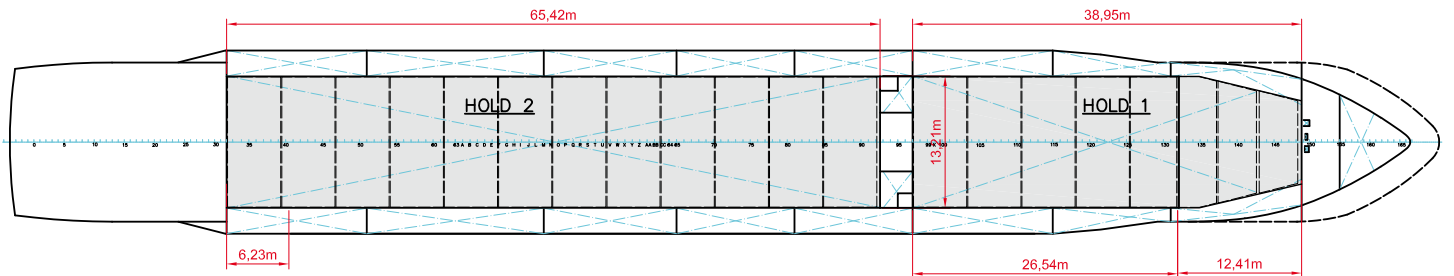

HOLDS & DOUBLE BOTTOM

