



Vessel name	Built	IMO no.	Flag	Vessel name	Built	IMO no.	Flag
BBC Holland	2002	9198616	Gibraltar	BBC France	2005	9197416	Gibraltar
Peter Roenna	2002	9198628	Gibraltar	Geise	2006	9195470	Gibraltar
BBC Sweden	2002	9278600	Gibraltar	BBC Romania	2006	9195420	Gibraltar
BBC Bulgaria	2004	9302061	Gibraltar				

## MAIN DATA

Vessel type	Multipurpose Tweendecker
Classification	GL + 100 A5 E3 G + MCE3 AUT strengthened for heavy cargoes, equipped for the carriage of containers, equipped for the carriage of dangerous goods
GT/NT	3,194 / 1,725
Deadweight (summer)	4,325 mt
Max. draft (summer)	5.74 m
Length o.a.	98.90 m
Breadth moulded	13.80 m
Depth to main deck	7.40 m
Height above keel	30.50 m
Speed	12.5 knots
Fuel consumption	11.0 mt RME 180 fuel per day at sea 0.7 mt MGO DMA per day in port without gear 1.2 mt MGO DMA per day in port with gear

## HOLDS/HATCHES/CRANES

Cargo hold capacity	6,371 cbm / 224,895 cbft
Floor space under deck	1,490 sqm / 16,038 sqft
Floor space on deck	790 sqm / 8,503 sqft
Cranes	2 cranes situated portside 60 mt capacity each / 120 mt capacity combined
Container intake	256 TEU nominal 161 TEU at 14 mt homogeneously loaded 20 reefer plugs on deck
Deck strengths per sqm	15.00 mt on tanktop 2.50 mt on tweendeck 1.60 mt on hatchcovers

>>> see reverse side for further info/details

## SPECIAL EQUIPMENT/FEATURES

Fitted for trading Great Lakes and Australia.  
Fitted for carriage of dangerous goods of all IMO classes.

Speed and consumption figures are calculated basis maximum Beaufort 2, no swell and no adverse currents. Consumption data assumes shaft generator and reefer plugs disconnected. Vessel is burning fuels according to ISO 8217-2005. Intake is always subject to vessel's stability, trim, permissible weights and is subject to regulations of visibility. Lifting capacity of vessel's cranes is subject to vessel's stability and can depend on cargo/ballast on board. Container data as well as bale capacity assumes tweendeck ashore. All details including speed and consumption are given in good faith and are „about“ and are given without guarantee. They must not be used as basis for charterparties or contracts without BBC's explicit written authority.

Crane working area SWL 35t

BBC Holland	BBC France
Peter Roenna	Geise
BBC Sweden	BBC Romania
BBC Bulgaria	

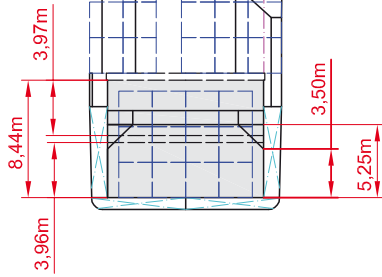

**SIDE VIEW**

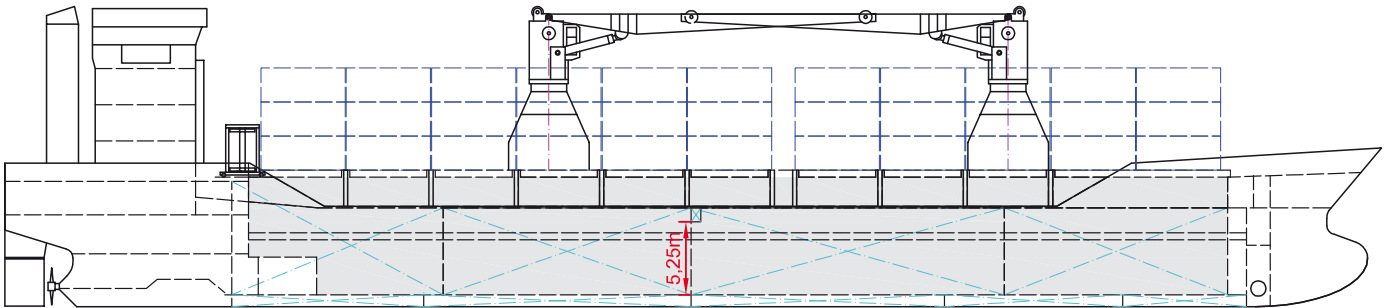

**MAIN DECK**

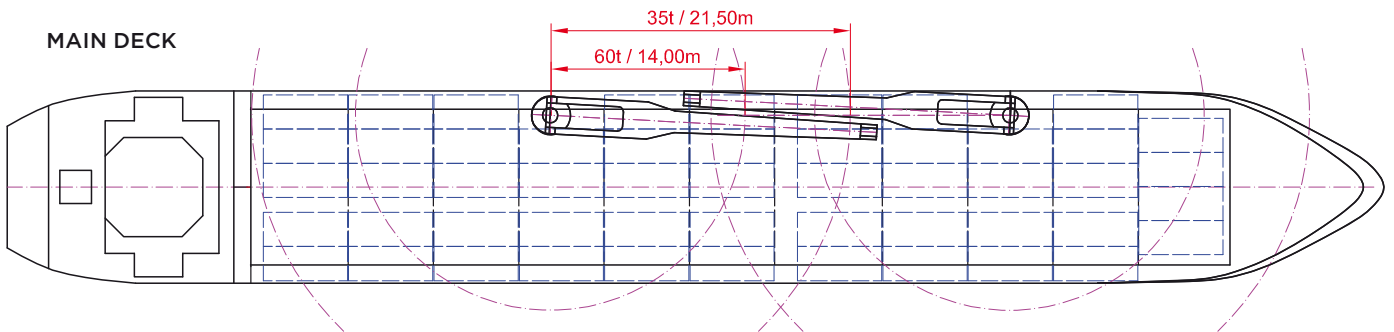

**TWEENDECK**

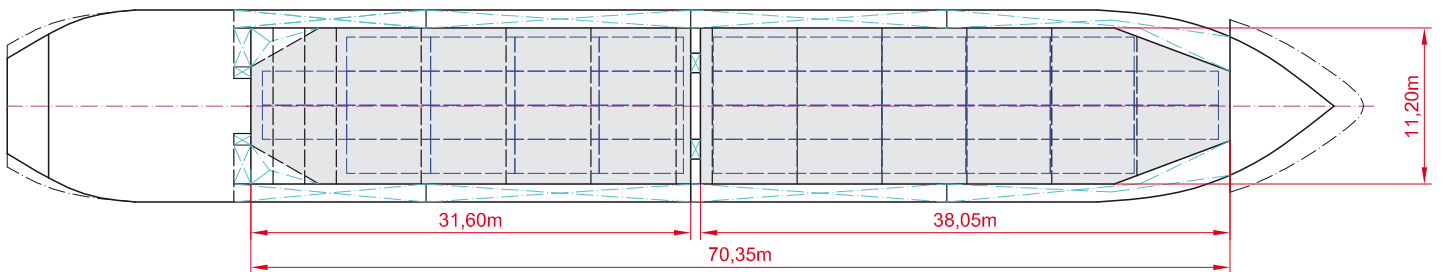

**HOLDS & DOUBLE BOTTOM**

